

# PCB BIT GRINDING SPINDLE MOTOR CHCNC2000-A

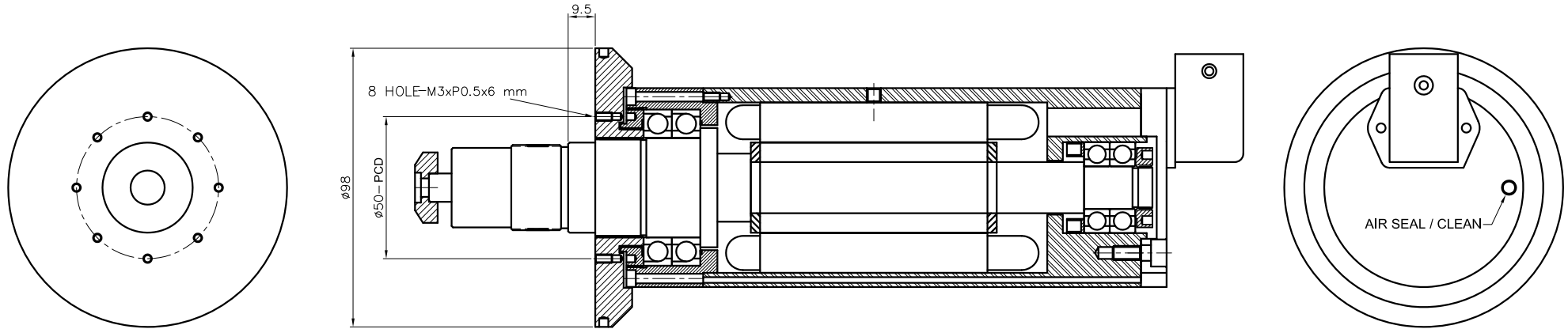

## PCB BIT GRINDING SPINDLE MOTOR FEATURE :

1. POWER (KW) : 0.75
2. CURRENT (A) : 3
3. VOLTAGE (V) : 200
4. RADICAL VIBRATION : 0.002 mm . AXIAL VIBRATION : 0.001 mm
5. RATED SPEED (RPM) : 4500
6. MAXIMUM SPEED (RPM) : 9000
7. NATURAL COOLING
8. DYNAMIC RUN OUT G0.4
9. AIR SEAL
10. UNDER THE NORMAL WORKING CONDITIONS THE APPLICATION TEMPERATURE OVER 50°C ,THE TEMPERATURE RISE IS NOT SMALLER THAN 18°C .

### Torque-diagram

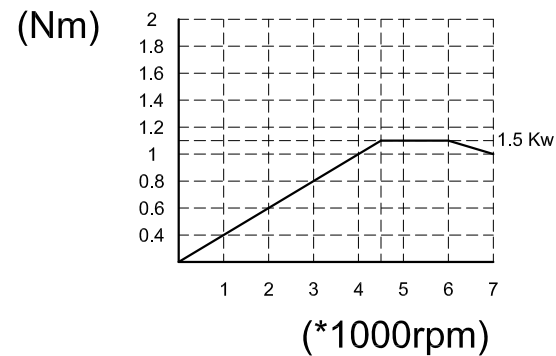

### Power-diagram

